

**MADE IN  
GERMANY**

For more than 65 years



**Lammers**

Formen- und Maschinenbau GmbH & Co. KG



**WE ARE  
SHAPING  
YOUR  
IDEAS**

Moulds for the  
concrete block industry







# WE ARE SHAPING YOUR IDEAS

For more than 65 years, company Lammers is manufacturing different products at the company headquarters in Haren-Erika, in the northwest of Germany.

50 years ago, we specialized in mould construction for the concrete industry.

The continually growing know-how our more than 50 high qualified employees and the deployment of the latest manufacturing technology enables us to meet the requirements relating to the mould construction together with individual customer wishes.

Our increasing base of customers is distributed worldwide which is proof for our close partnership with the concrete industry.

# PAVING STONE MOULDS

- ✓ inlet made in one block with small tolerances
- ✓ special hardening up to 65 HRC; 1,2 mm deep
- ✓ tamper feet's screwed

## options

- ✓ heating tamper shoes
- ✓ tamper shoes with rubber buffers
- ✓ pulling sheet
- ✓ dynamic inlet



FRAME TYPE  
**LF Multi 2**

- ✓ inlet with frame is screwed
- ✓ frame with mold pick up and rails welded

## options

- ✓ changeable screwed top plates



FRAME TYPE  
**LF Type 3**

- ✓ inlet with frame made in one block
- ✓ mold pick up and rail made as one screwable module
- ✓ changeable screwed top plates









# CURB- STONES

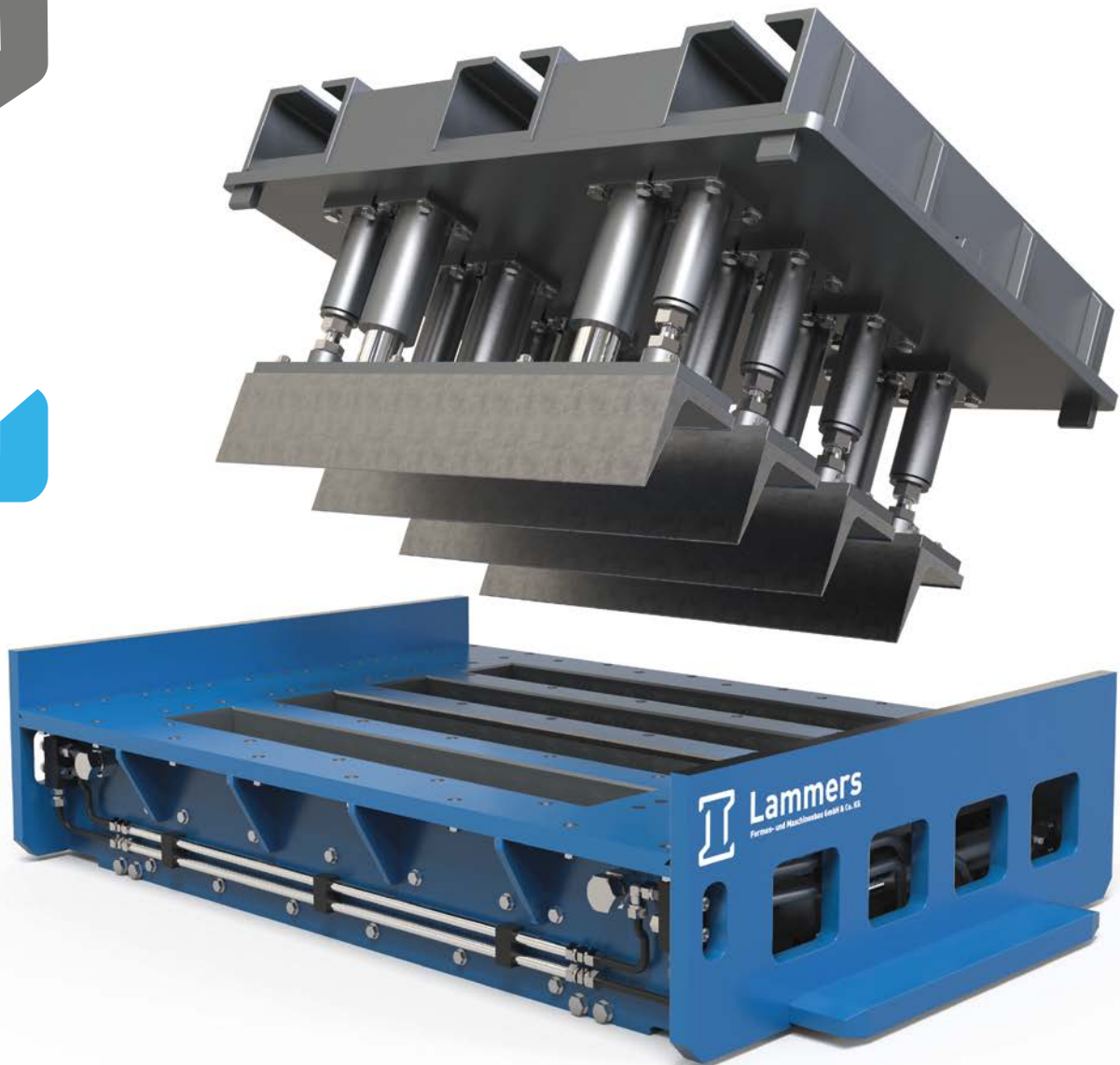

- ✓ inlet in module construction welded or screwable
- ✓ frame with mold pick up and rails as welded module
- ✓ screwed tamper feet

**options**

- ✓ pneumatic tamper compensation
- ✓ hydraulic displacement wall

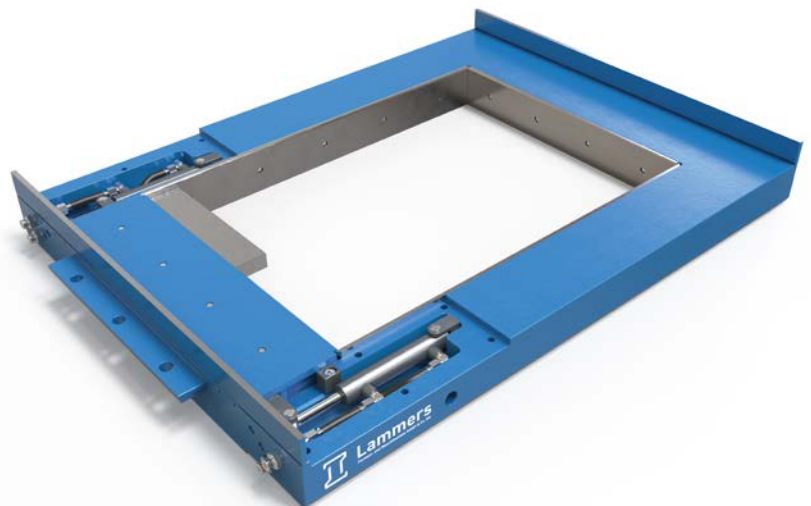



# MEBA AND HOLLOW BRICK MOULDS



## MOULD MEBA

- ✓ inlet made out of one block with minimal tolerances
- ✓ special hardening up to 65 HRC; 1,2 mm deep
- ✓ tamper feet screwed or welded
- ✓ cores and core bars in module construction welded or screwable

### Options

- ✓ pulling sheet



## MOULD HOLLOW BRICK

- ✓ inlet in module construction welded or screwable
- ✓ frame with mold pick up and rails welded
- ✓ cores and core bars in module construction welded or screwable
- ✓ tamper feet screwed or welded





**Lammers**  
Formen- und Maschinenbau GmbH & Co. KG





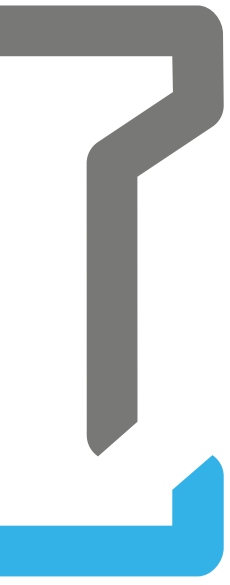

LAMMERS



# CLEVER CHANGE

- ✓ system for infinite amount of forms
- ✓ modular design
- ✓ fast and easy exchange of bolted components
- ✓ less storage capacity needed than in conventional designs

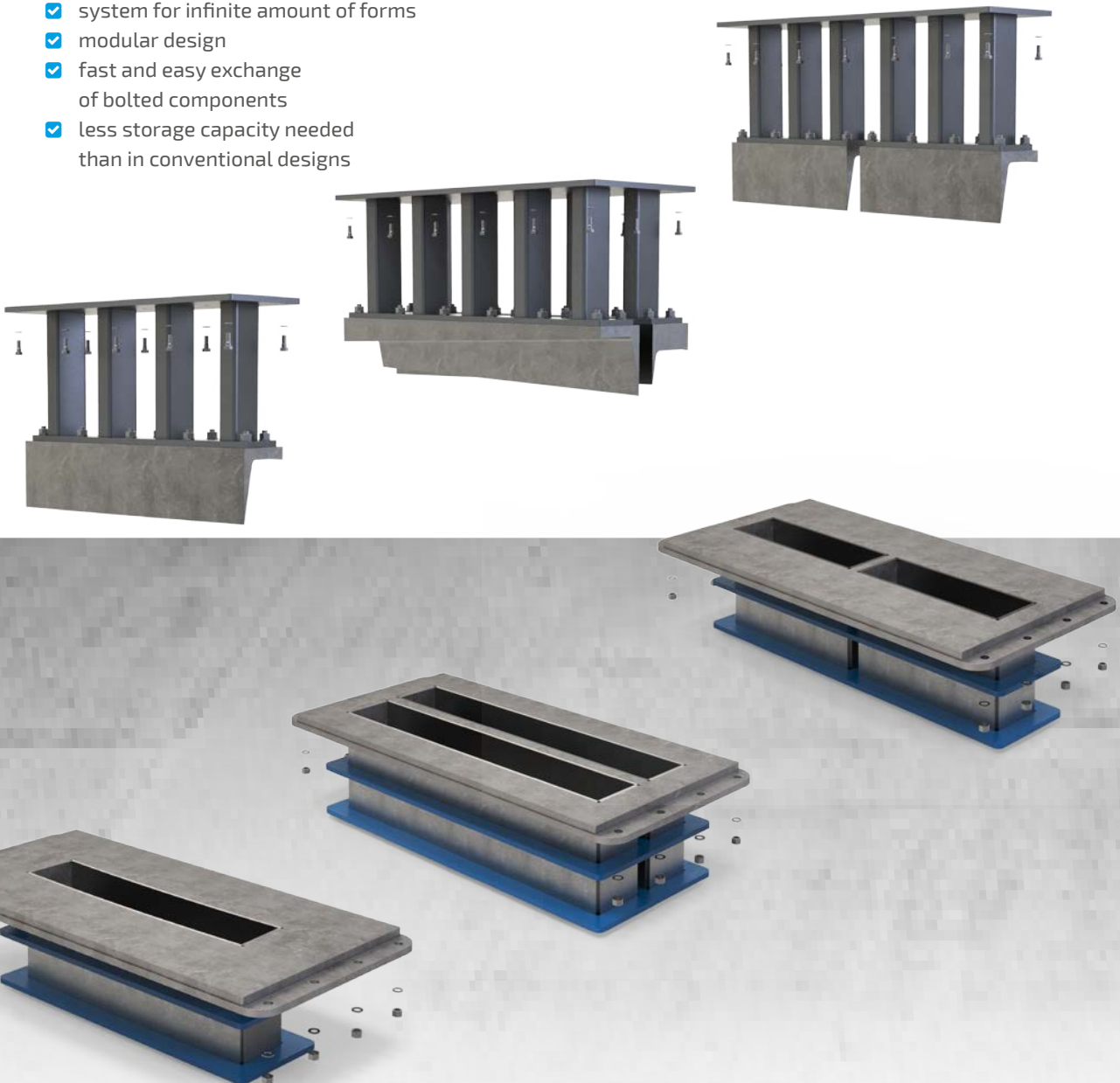



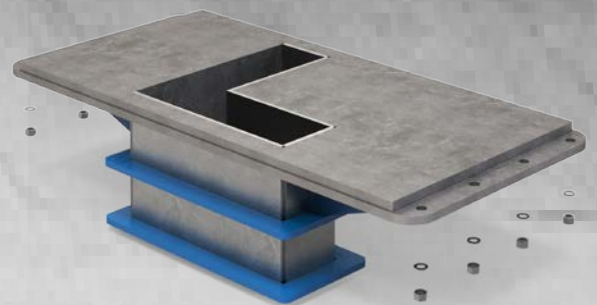
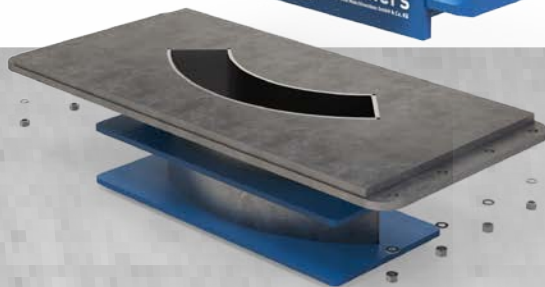
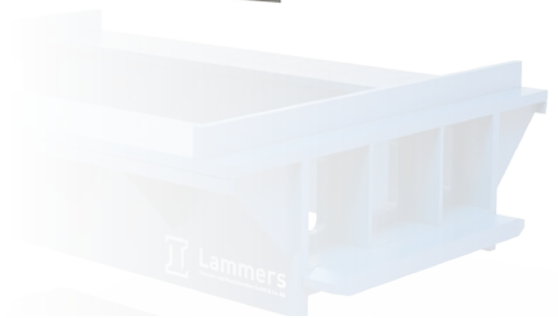
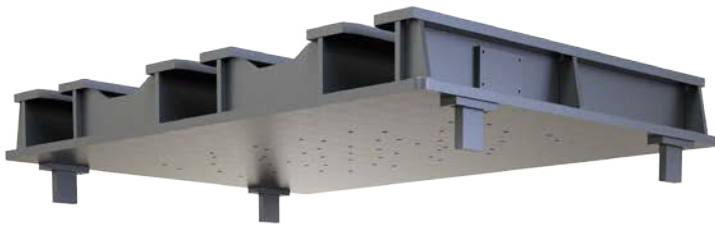





HOT!



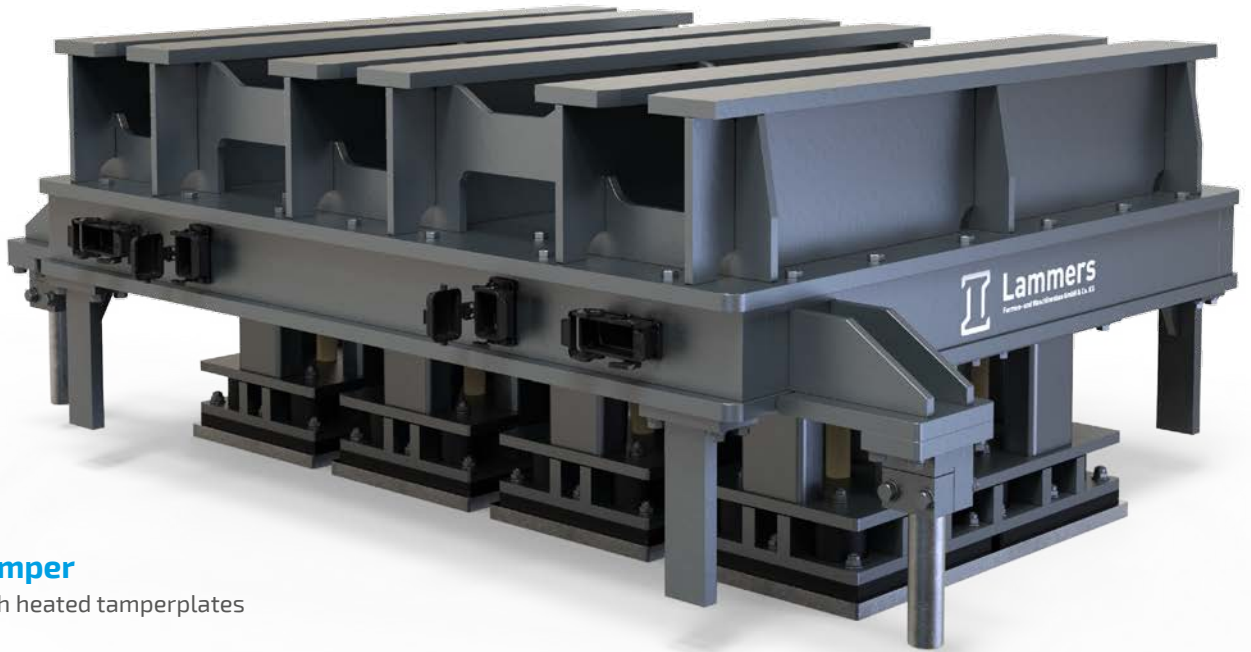

**Tamper**  
with heated tamperplates



**Tamperplates**  
with embossed surface



# BEST IN SHAPE







**Lammers**  
Formen- und Maschinenbau GmbH & Co. KG





# Lammers

Formen- und Maschinenbau GmbH & Co. KG

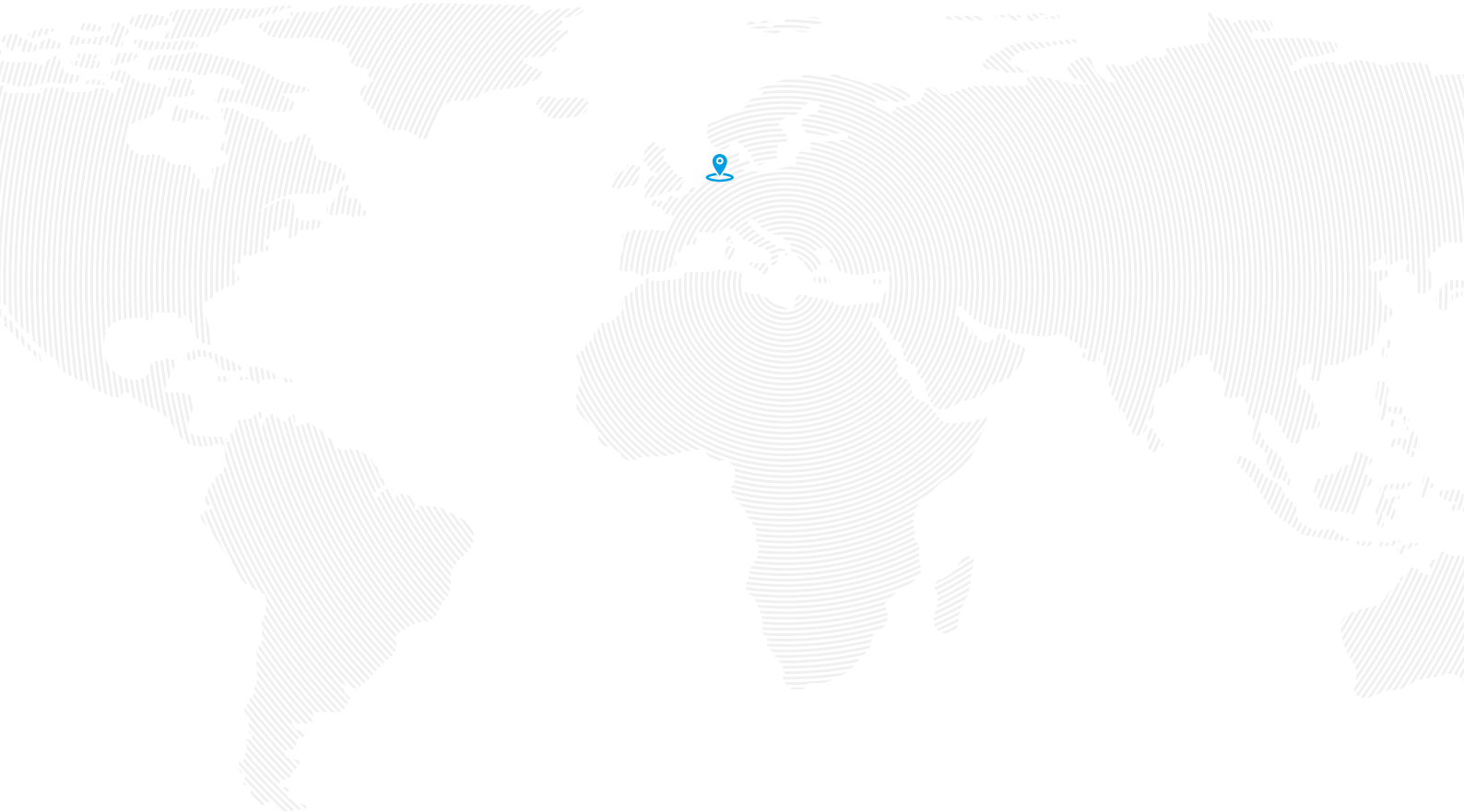

**LAMMERS Formen- und  
Maschinenbau GmbH & Co.KG**

Oberlangener Straße 13-15  
D-49733 Haren-Erika  
Germany

**PHONE** +49(0)5934 9350-0  
**FAX** +49(0)5934 9350-50  
**MAIL** [info@lammers-formenbau.de](mailto:info@lammers-formenbau.de)

We are shaping your ideas  
[www.lammers-formenbau.de](http://www.lammers-formenbau.de)